

**COMPACT ISO 21287
PNEUMATIC CYLINDERS
KC-A SERIES Ø32- Ø100**

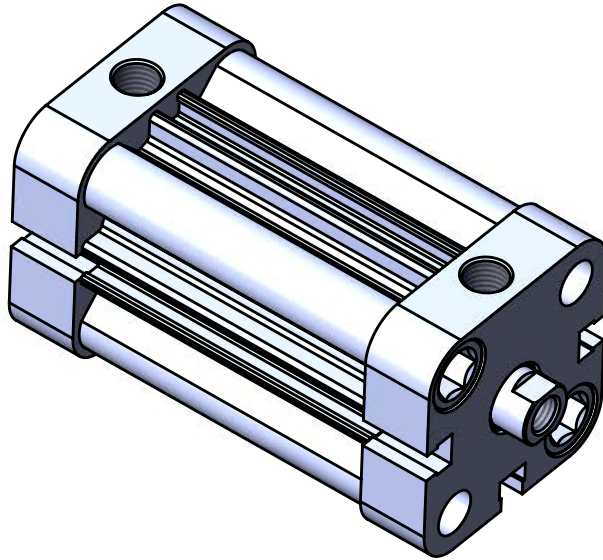

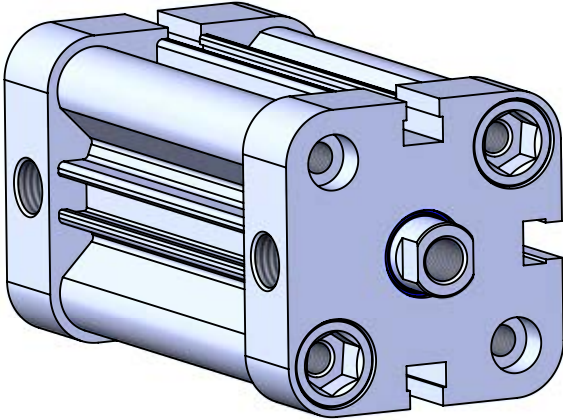

KC -A SERIES

COMPACT - Ø32 - Ø100 - ISO 21287

COMPACT MAGNETIC CYLINDER

NEED HIGHER POWER IN A TIGHTER SPACE? KC-A IS THE PERFECT CHOICE

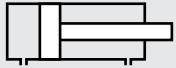

KC: COMPACT CYLINDERS WITH DOUBLE ACTING

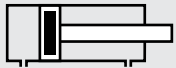

KC-A: MAGNETIC COMPACT CYLINDERS WITH DOUBLE ACTING

Example of order:

KC-A 032-025 K1 M1
Product code Cylinder Ø Stroke Variants from Standard System

Variants from standart system:

- R1: Stainless Steel Piston Rod (SS 304-SS 316)
- R4: Stainless Steel Nut for Piston Rod (SS 304)
- R5: Piston Rod as CK45 (Hard Chrome Plated)
- M1: Extended male Piston Rod Thread
- M3: Special Piston Rod Thread
- M4: Extended Piston Rod
- K1: Seals for Max. 150°C (Viton)
- K4: Piston Rod Seal Viton

Force:

Cylinder Ø mm	Rod Ø mm	Thrust and traction forces (6 Bar)	
		Thrust force (N)	Traction force (N)
32	12	482	415
40	12	754	687
50	16	1178	1058
63	16	1869	1750
80	20	3014	2829
100	20	4710	4522

Working Fluid:

Filtered and lubricated or filtered and not lubricated air.

Operating Temperature Range:

Polyurethane (PU) : (-20°C) - (+80°C)
Viton (FKM) : (-30°C) - (+150°C)

Maximum work pressure:

10 Bar

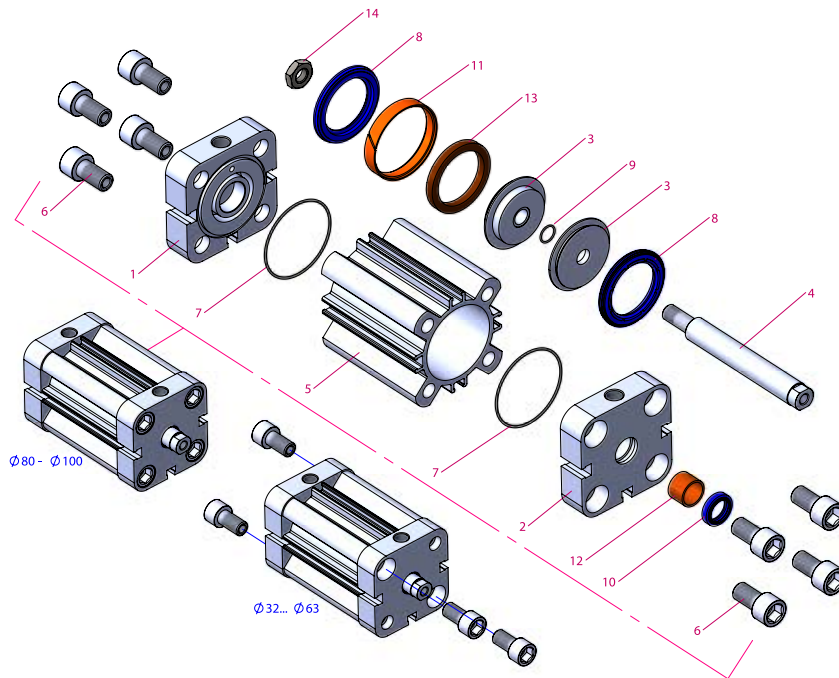
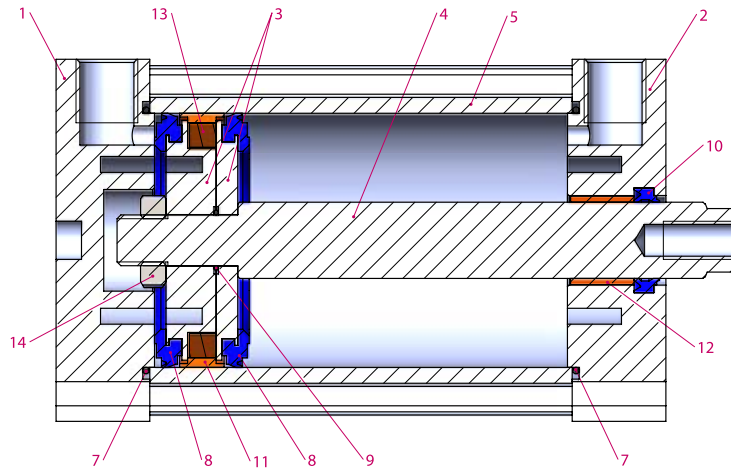

No	Material name	Characteristic	Pc.
1	Rear Head	Aluminium	1
2	Front Head	Aluminium	1
3	Middle Piston	Aluminium	2
4	Piston Rod	X20Cr13 Hard Chrome Plated	1
5	Tube	Al Mg Si 0,5 + Eloxal Plated	1
6	Bolt	SS 303	4-8
7	Head O-ring	NBR	2
8	Piston Seal	PU	2
9	Middle Piston O-ring	NBR	1
10	Rod Seal	PU	1

No	Material name	Characteristic	Pc.
11	Guiding Band	Polyacetal	1
12	Guiding Bush	CSB-40	1
13	Magnet		1
14	Nut	Galvanized Steel	1

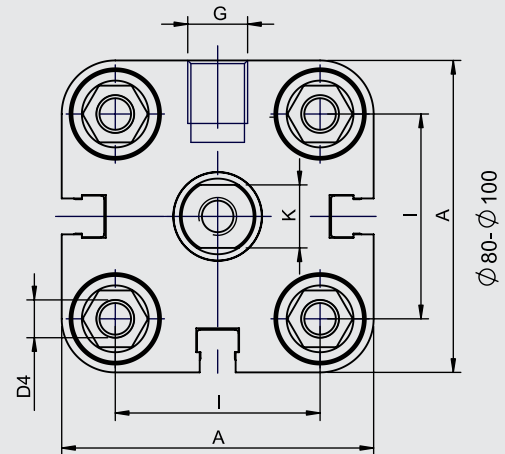
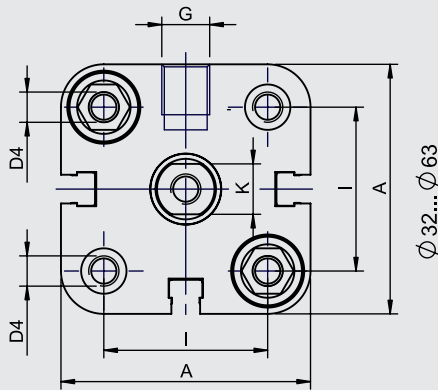
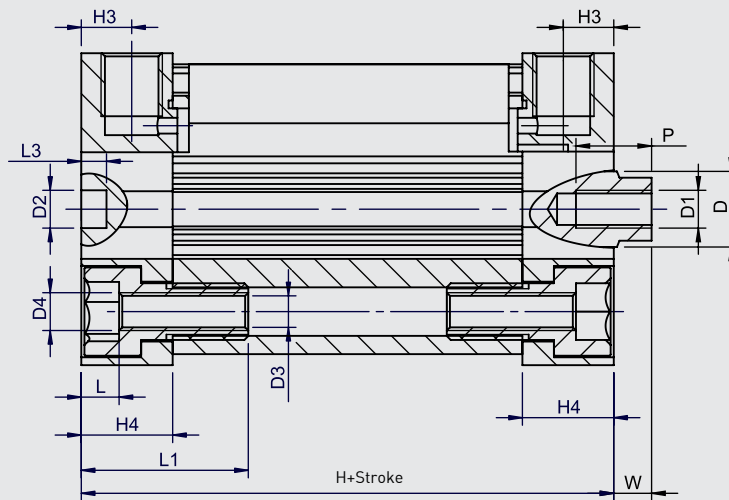

Cylinder Ø mm	A	D Ø	D1 Ø	D2 Ø	D3 Ø	D4 Ø	G	H	H3	H4	I	K	L	L1	L3	P	W
32	49.5	12	M8	6	5.2	M6	1/8"	44.5	7,5	14.5	32.5	10	6	26.5	4	12	7
40	57	12	M8	6	5.2	M6	1/8"	46	7,5	14.75	38	10	6	26.5	4	12	7
50	65.5	16	M10	6	6.8	M8	1/8"	46.5	7,5	14.75	46.5	13	7	30.5	4	16	8
63	79.5	16	M10	8	6.8	M8	1/8"	50	7,5	14.75	56.5	13	7	30.5	4	16	8
80	96	20	M12	8	8.5	M10	1/8"	56.5	8,25	16.5	72	17	8.7	38.5	4	20	10
100	116	20	M12	8	8.5	M10	1/8"	67	10	19.75	89	17	8.7	38.5	4	24	10

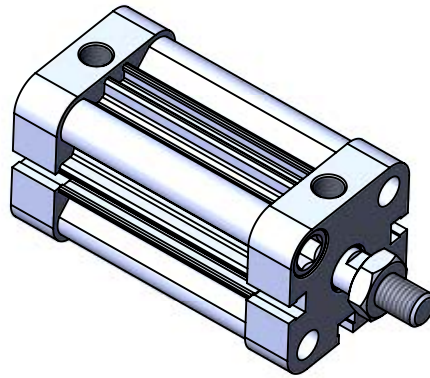

KC-T

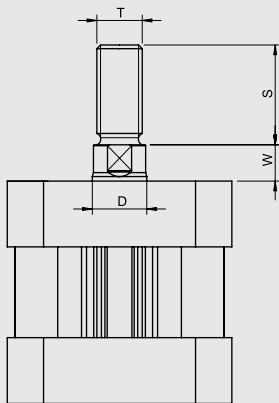

KCS-T

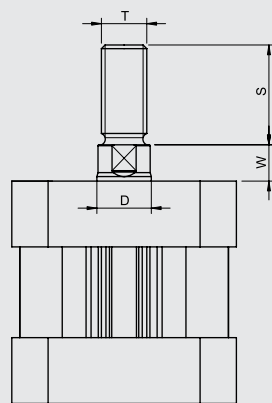

KCE-T

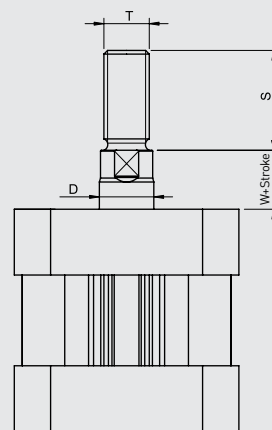

KCD-T

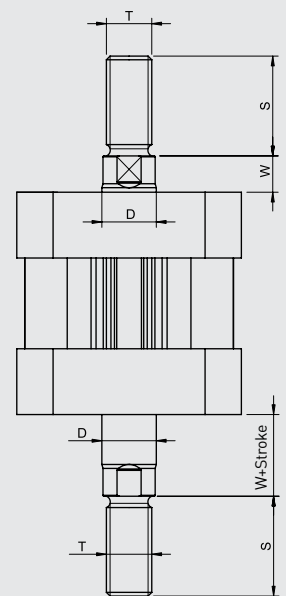

Cylinder type	Cylinder Ø mm	D	S	T	W
KC-KCS KCE-KCD	32	12	19	M10x1.25	7
	40	12	19	M10x1.25	7
	50	16	22	M12x1.25	8
	63	16	22	M12x1.25	8
	80	20	28	M16x1.5	10
	100	20	32	M16x1.5	10